

MORARA

MH 2000
MH 3000



AEROSPACE APPLICATIONS

Universal Cylindrical Grinding Machines

Grinding Technology





MH 2000 - MH 3000

- External-Internal heavy-duty grinding machine with moving table and 1 wheel carriage
- Max. weight between centers 1500 (2500) kg
- Swing max. 600 /(1040) mm
- Available in two sizes between centers
- Wheelhead configurable with various additional options

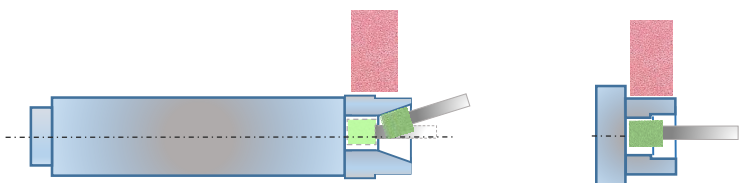
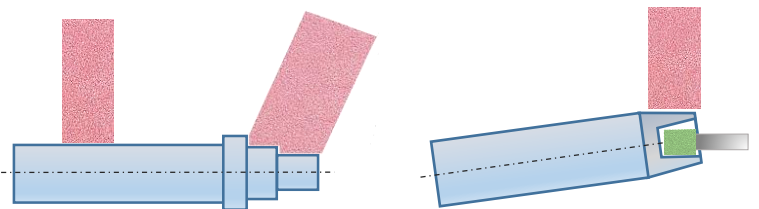
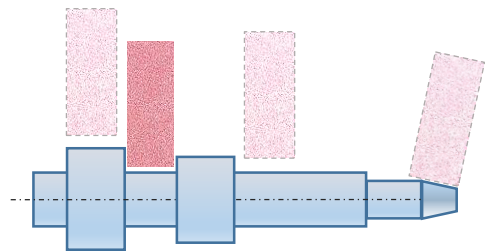
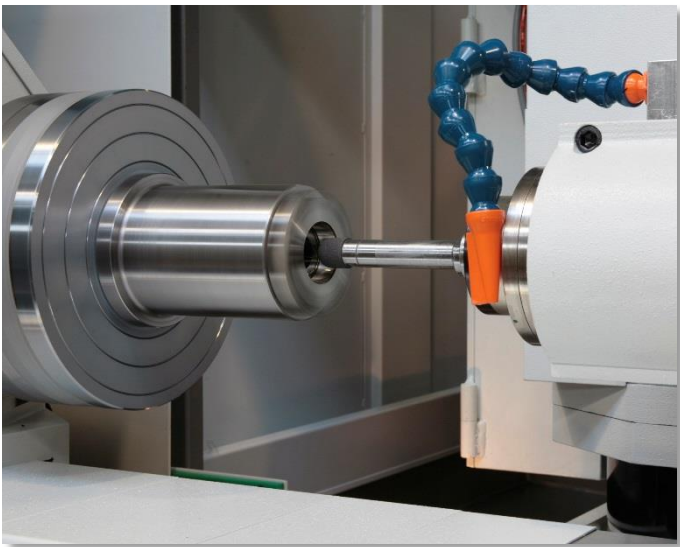
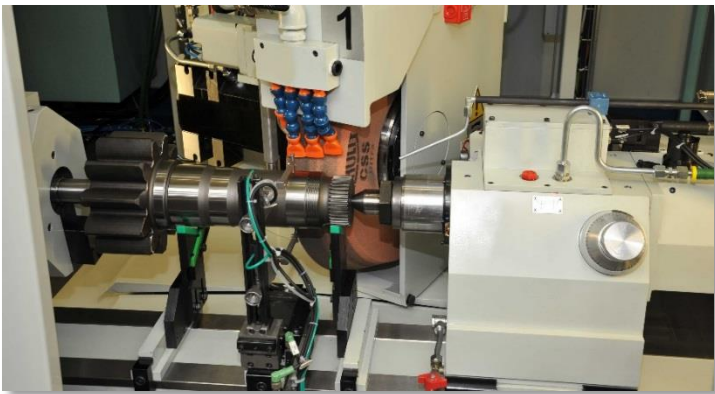

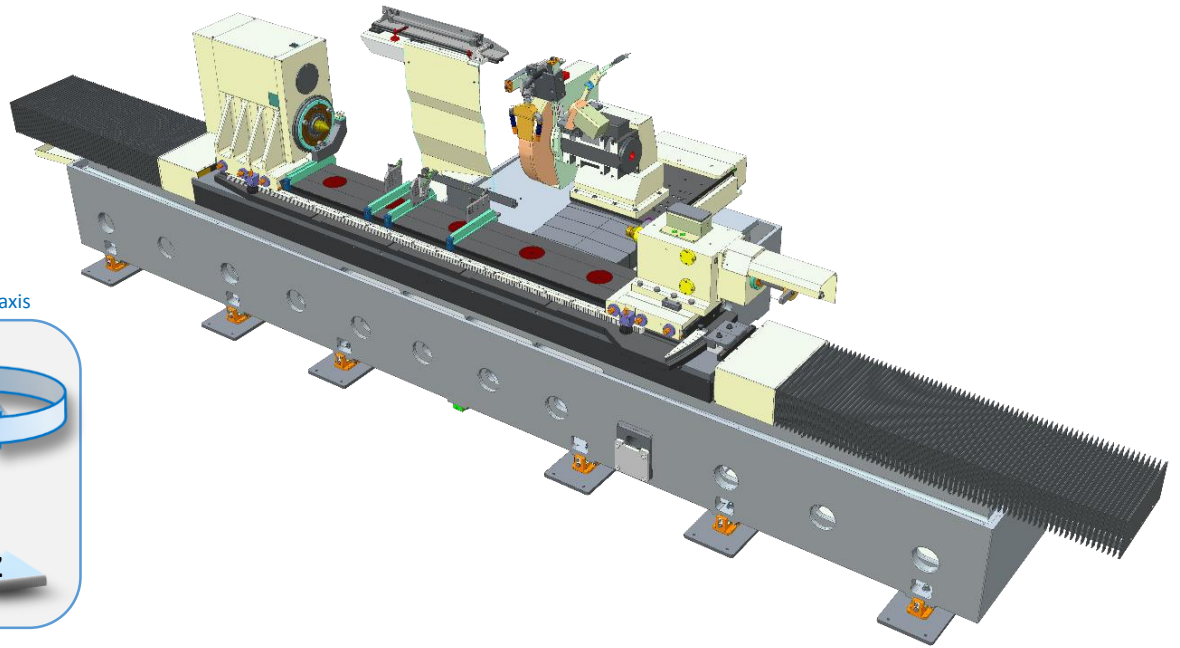

Swivelling guide is over X axis

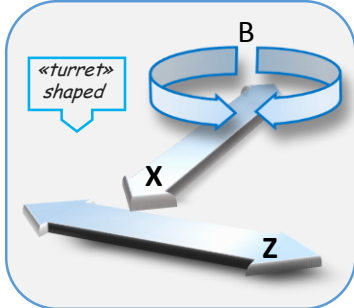

Capacity between centers	mm	2000 – 3000
Centers height	mm	330 - 525
Max. weight between centers	Kg	1000 - 1500 -2500
External wheel	mm	610x120x203,2 -- 760x150x304,8
Internal spindle	rpm	from 6.000 to 30.000 – 60.000







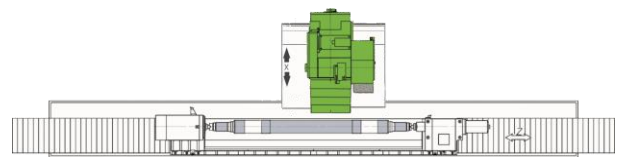

Tab. 1

MH 2000

MH 3000



- Automatic swivelling wheelhead with **B axis** (torque motor)
- Available in different wheelhead configurations, which makes it possible to use multiple tools.

FIXED WHEELHEAD	 AUTOMATIC SWIVELLING WHEELHEAD							
								
LS	L/L-B	L/I-B	LR/I-B	L/R-B	L/I/R-B	R/I/I-B	LR/L-B	
0°	-20°+ + 230°	-20°+ + 230°	-20°+ + 230°	-20°+ + 230°	-20°+ + 230°	-20°+ + 230°	-20°+ + 230°	
Max.Wheel diameter (mm)	760	760	760	760	610	610	760	610

-Created to meet the most diverse grinding needs, from small to high productions.

-Able to grind diameters from 50mm to 600 / (1040)mm, piece length up to 3000mm, 300mm internal deep holes with our standard spindles and quill.

-Grinding of external and internal diameters and tapers in a single placing, including external and internal face grinding.

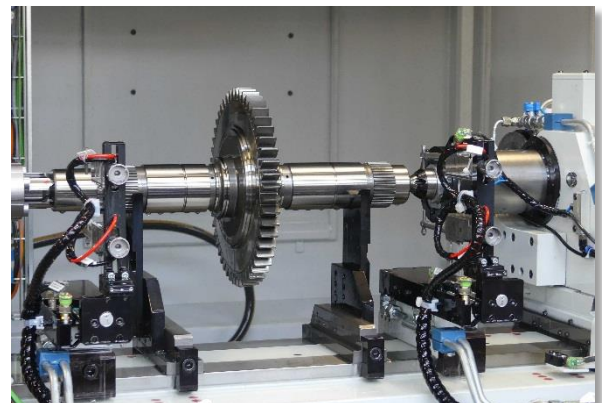
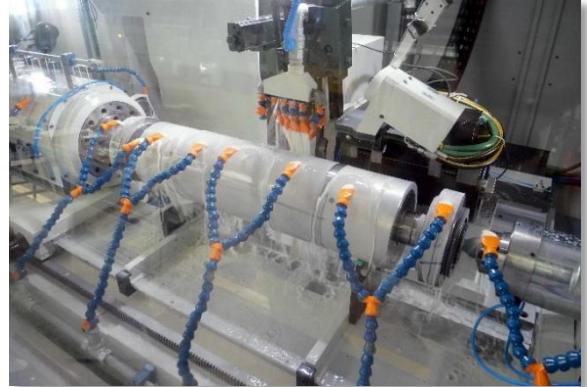

- **Stabilized cast-iron base** with hand-scraped guideways and peripheric channels for coolant recovery and conveyance
- Machine mainframe is designed using 3D solid parametric modelling techniques and FEM analysis
- **The wheelhead (X Axis)** slides on extra-precise re-circulating rollers or **hydrostatic self-adjusting guideways**;
- Transversal movement by high precision recirculating ball screw driven through coaxial couplings by A.C. BRUSHLESS-Motor or Linear Motors, feedback resolution 0,0001 mm with absolute linear transducer
- **The table (Z Axis)** slides on flat prismatic slideways with interposition of antifriction material to eliminate stick-slip phenomena; longitudinal movement by high precision recirculating ball feed screw driven through coaxial couplings by A.C. BRUSHLESS-Motor; resolution 0,0001 mm;

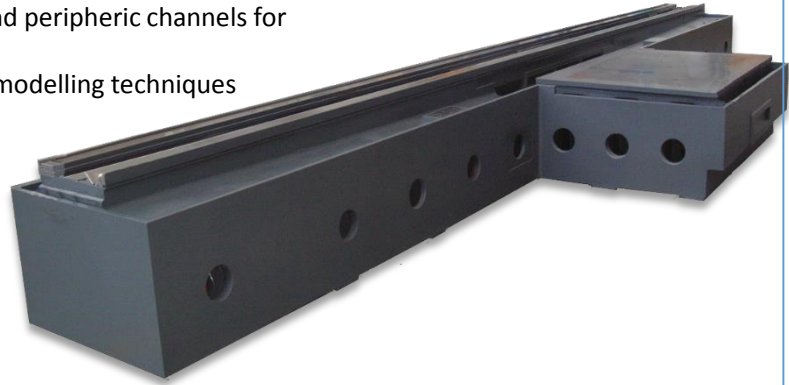

- **Swivelling Wheelhead with B Axis** by means torque servomotor Resolution 0.0001 °, for the automatic orientation of the grinding wheel head on any angular position, freely programmable, between + 20 ° and -210 °, for face/ external grinding operations and internal grinding (see selected options) .
Automatic unlocking / locking device "**Quick Clamp**".

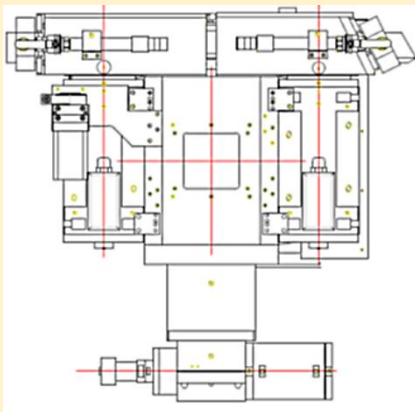

«turret»
shaped

- **OPTIONAL:**
Swivelling Table micrometric table swivelling graduations adjustment device, complete with dial indicator
For model 2000 only, max. 7°,



Spindles grinding wheel on bearings

- Integrated motor
- Double end or single end WheelSpindle nose, arranged to receive inside the wheel dynamic balancing device
- Rotating on high precision ball bearings

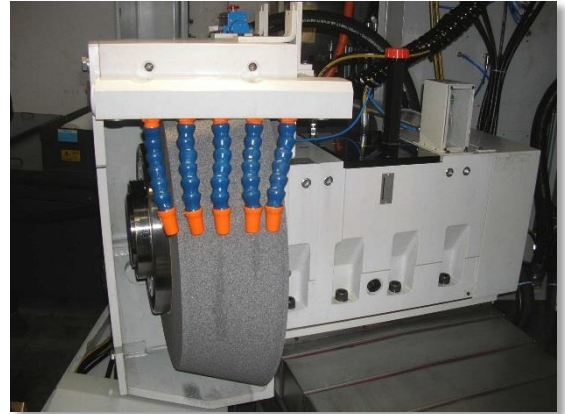
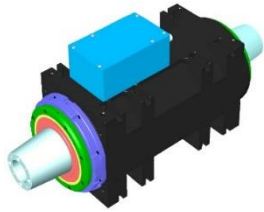

External wheel dynamic balancing device

- To correct the negative effects directly on the grinding spindle optimizing the surface and the quality on the grinded piece.
- Increases machine productivity
- Increases spindle and grinding wheel life
- Increasing the interval between the dressing/pieces, reduces the environmental impact
- Manual checks are not necessary

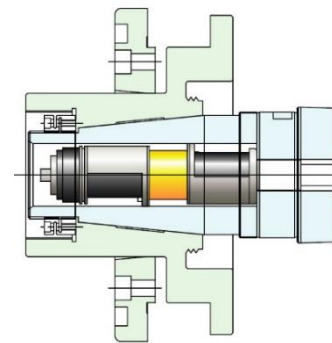
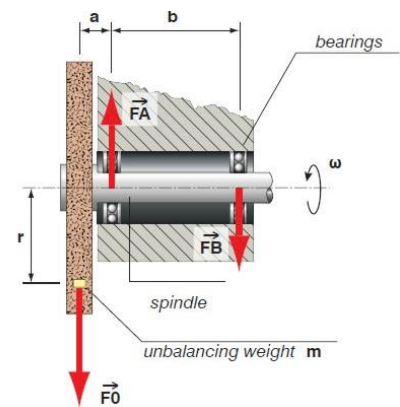

Super-finishing device (OPTIONAL)

- With abrasive belt
- Ajustable speed oscillation

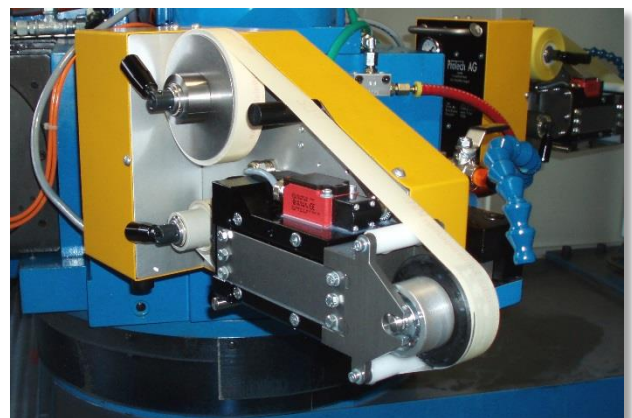
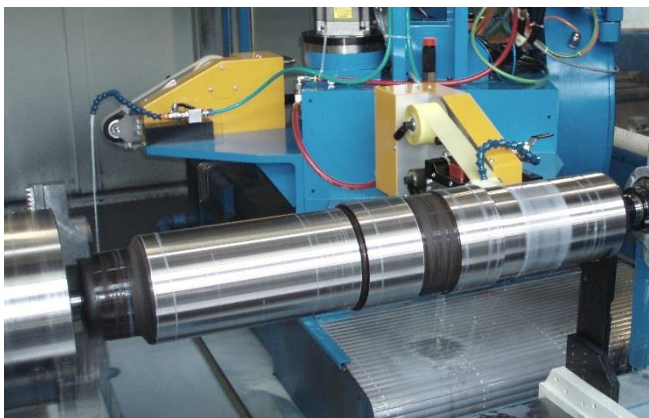

Wheel protection with wear compensation device

- In compliance with international safety regulations, the wheel mobile guard must be placed at a distance of no more than 6 mm from the grinding wheel.
- The peripheral speed compensation is automatic, calculated on the basis of the wheel wear. The mobile upper guard and coolant nozzle are held in position at the correct distance from the grinding wheel whenever the diameter of the latter decreases due to the effect of the dressings.
- The position of the wheel upper guard is determined by an absolute transducer (potentiometer) which transmits the device movement to the NC.
- The upper guard position controls the real diameter and the variation of the wheel revolutions; in this way the peripheral speed is kept constant and the wheel programmed speed is always guaranteed.

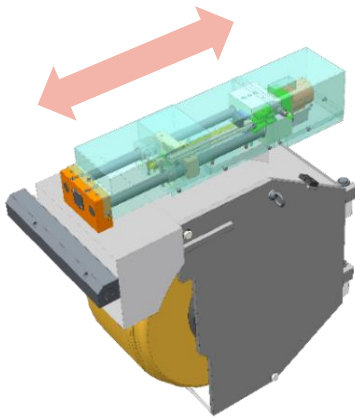

Accessories: Articulated arm for wheel change

- The articulated arm, placed near the machine, allows easy disassembly/reassembly of the grinding wheel in total safety.

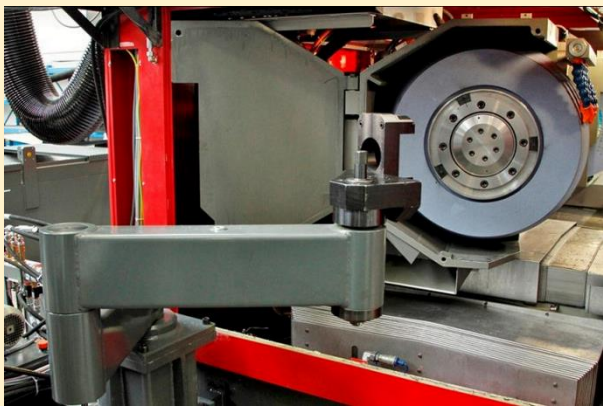

OPTION:
Multi-wheel support trolley

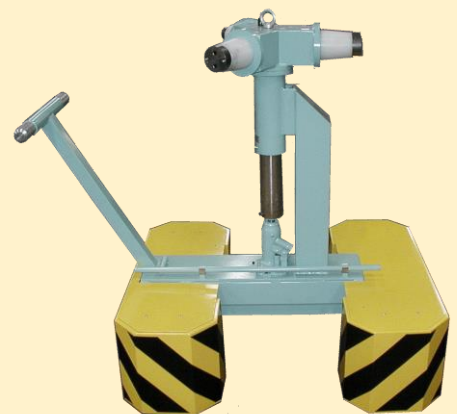

Workhead

UNIVERSAL:

- 50 Nm - 400 rpm (870 Nm - 200rpm)
- ASA6 / Morse6
- 250 (700)Kg at 100mm
- Dead and live centre

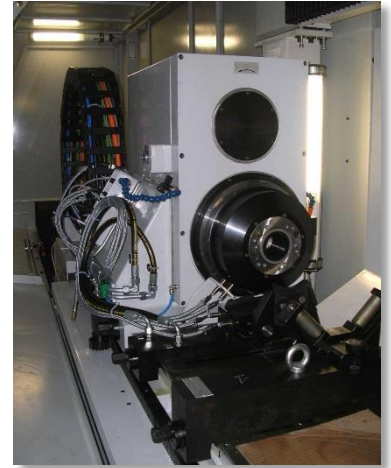
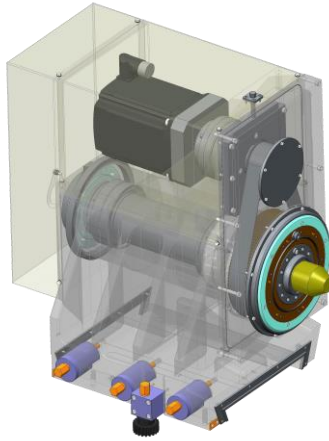

OPTION:

- Live centre
- Up to 100 Nm 1000 rpm
- ASA6 – ASA11
- 250 (400) Kg at 100mm
- C axis option

OPTION:

- Live centre
- Up to 870 Nm 200 rpm
- ASA11
- 1000 Kg at 100mm
- C axis option



Accessories

- Self-centering chuck

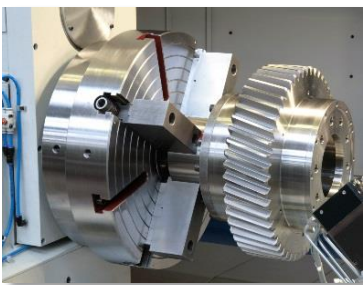

- Chuck with floating jaws

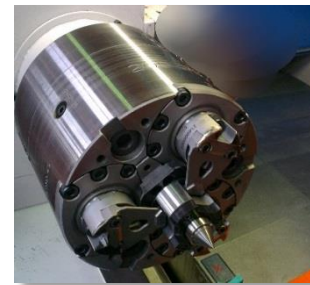

- Face Driver with 4 driving pins



- Special driver



STANDARD

- Tailstock morse 4-5
- Quill 100mm diameter
- 250 -700 Kg
- Quill stroke: 100mm
- Automatic hydraulic opening

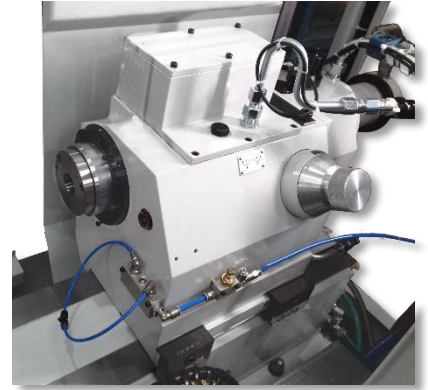
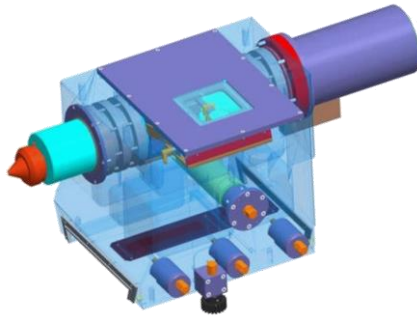

OPTION:

- Tailstock morse 6
- Quill 140mm diameter
- 1000-1500-2500 Kg
- Quill stroke: 120mm
- Automatic hydraulic opening
- **Motorization for live center (optional)**

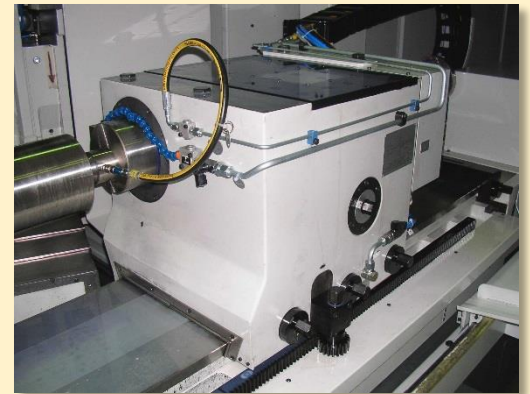
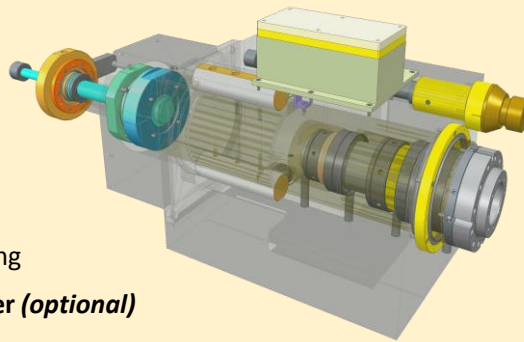

- A special hydraulic circuit is designed to guarantee the workpiece between centers and regulates the axial force during grinding operation.

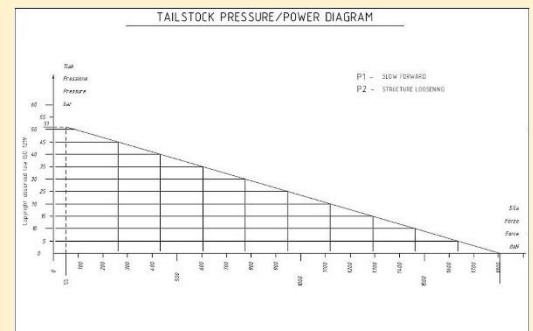

Accessories



- Mandrel for tailstock mounted on high precision bearings with exchangeable carbide tips.

- Integrated motor
- Grease lubrication
- Air oil lubrication (*optional*)
- Hybrid ceramic bearings (*optional*)
- Automatic quill wheelhead recognition **on our standard spindles** (from 6.000 to 30.000 rpm)
- Spindles up to 90.000 rpm (*optional*)
- *Extra long Spindles with integral coupling shaft for deep boreholes (optional)*

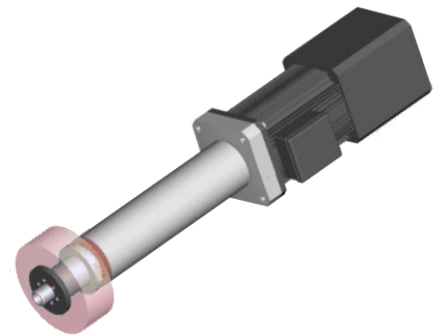
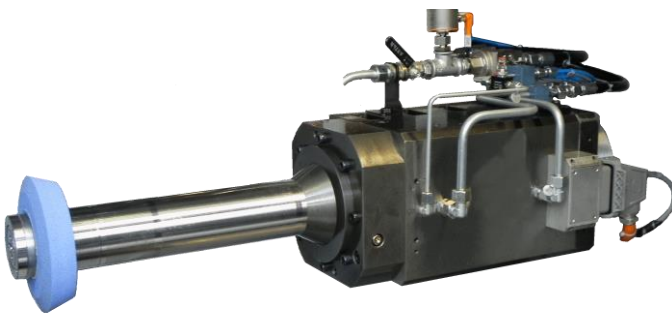
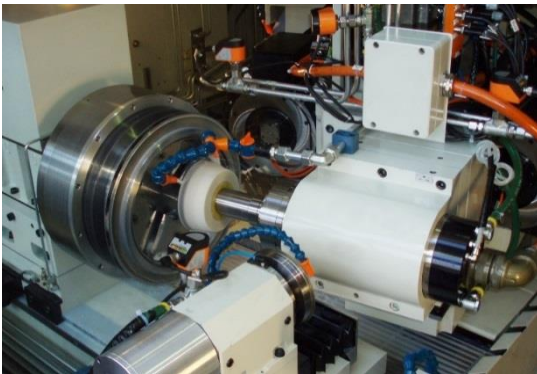
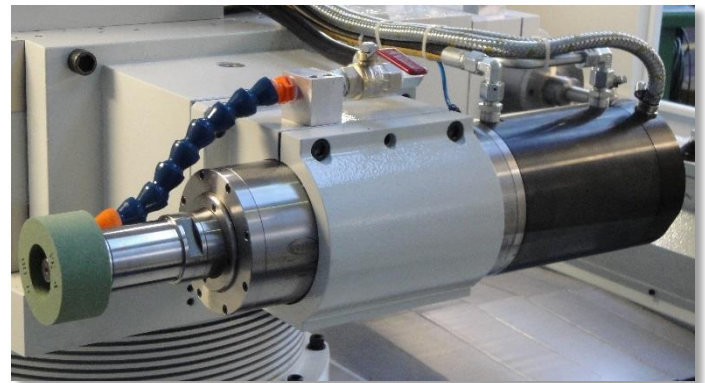

- Quill adapters
- Collet Holder and collet



- Fixed on the longitudinal table or on the workhead or tailstock to dress and profile the face/external grinding wheel
- Single point diamond for internal grinding
- Diamond 6 stone for fine dressing

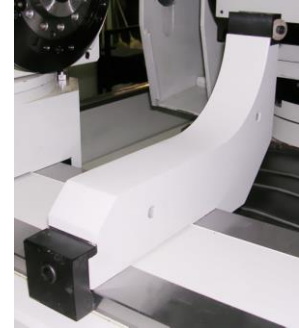

- **AUTOMATIC WHEEL DRESSING UNIT** for internal/external wheels with automatic engagement, mounted on the table

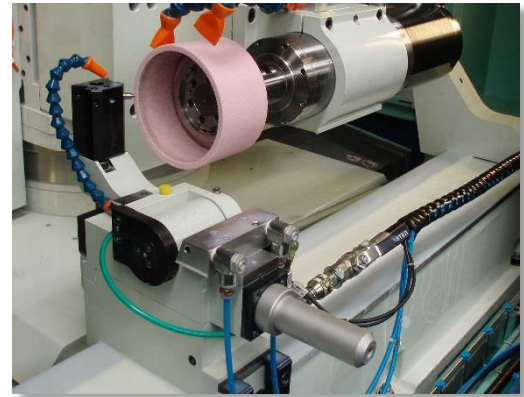

Engage position for dressing

- **OPTION:** **DIAMOND DISC UNIT** for internal wheels complete with highfrequency spindle support on the automatic wheel dressing unit

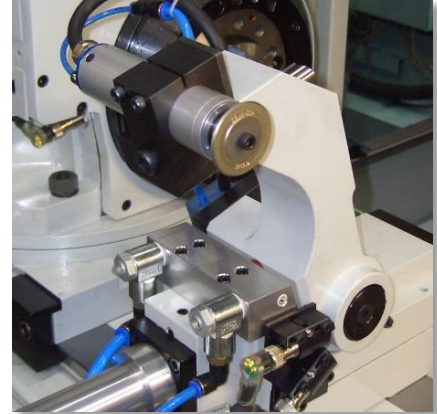

Desengage position for grinding

- **OPTION:** **DIAMOND DISC UNIT** for face/external wheels complete with highfrequency spindle support to be mounted on the table/tailstock



- **OPTION:** **PROFILE DIAMOND ROLLER UNIT** for external wheels complete with highfrequency spindle support to be mounted on the table/tailstock. For high-production.



- Steady-rest – for support long parts

Closed 3 points- steady rest



Open 2 points- steady rest



Automatic self-centering- steady rest

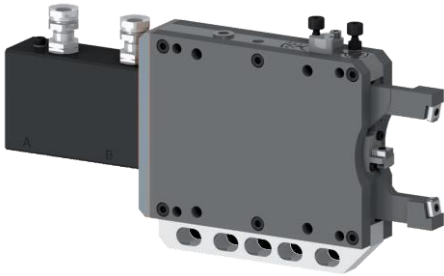

- Diameter Gauge on the table
- Axial Positioning on support to be fixed to the table (medium flexibility)

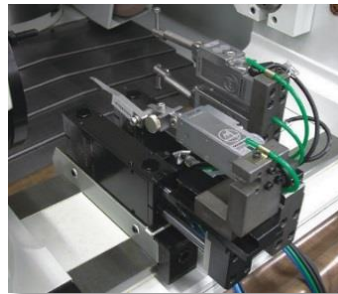

- Axial Positioning mounted on the wheelhead, complete with standard probe (High flexibility)



- Large-scale / multidiameter gauge (special with V axis)



- The Gap Eliminator detects the contact WHEEL-PIECE and simplifies the set-up operations on the first piece

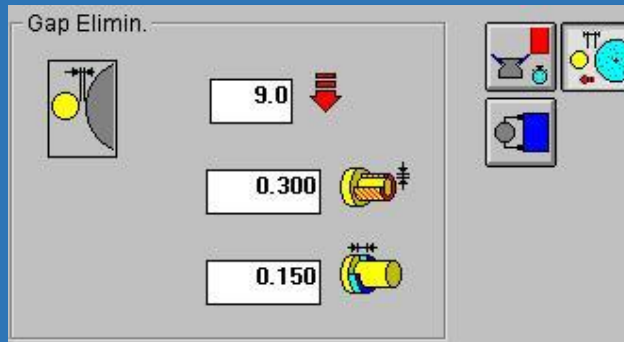

- The device reduces the cycle time optimizing the speed change of the set thresholds

- Multifunction graphic display for the optimization of the parameters of the touch and alarm thresholds, exchange and diagnostic signals

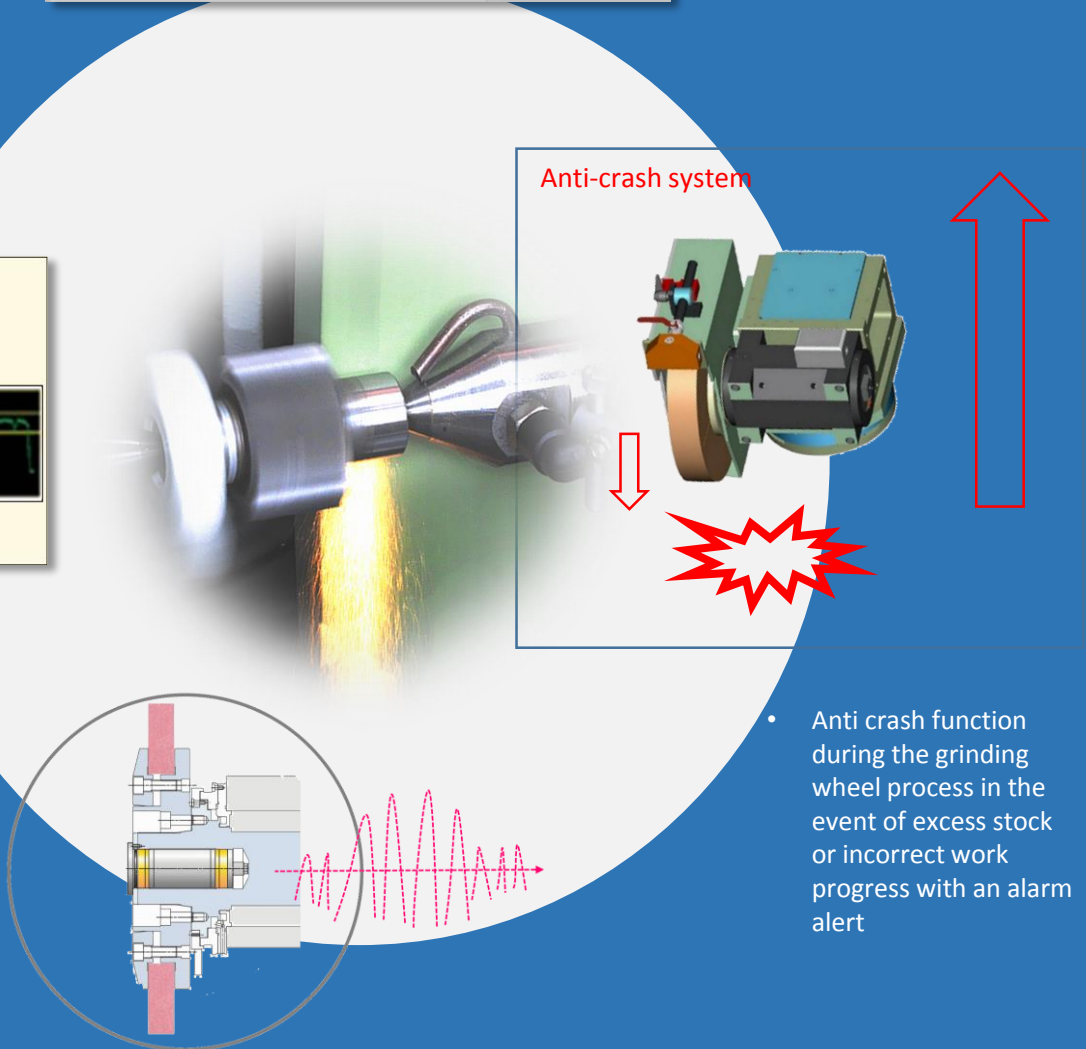
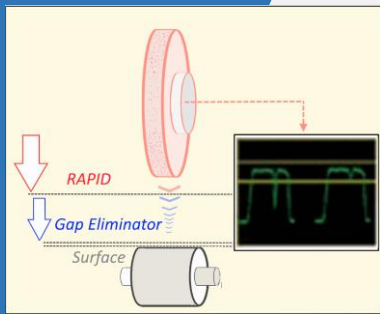

- Anti crash function during the grinding wheel process in the event of excess stock or incorrect work progress with an alarm alert

- The Gap Eliminator function is integrated and active on each wheel



- Adjustable on the right side of the operator with color monitor
- Machine control panel with selectors for "Override" axes movement and rotation of the workhead
- Mobile push-button with three-speed electronic handwheel (1; 10; 100 micron) switchable on the axes for machine set-up
- Quick and detailed diagnosis for main machine functions in "clear text".



- Equipped with interactive software T.O.P. (Tool Operator Package) controlling the automatic grinding cycles: roughing, semi-finishing, finishing and super-finishing in plunge, multiplunge and traverse cycles.
- Our dedicated to grinding interface leads the operator step by step to the complete management of the machine, easily and in compliance with safety regulations.

Human machine interface, developed on PC, uses a few and easy pages with graphic support.

The operator can set the operations to be performed for set-up trough appropriate wizards and for the execution of all the available processes.

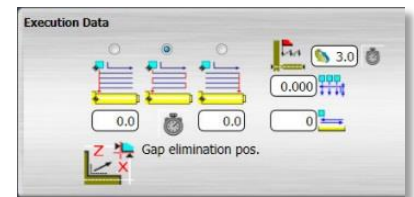
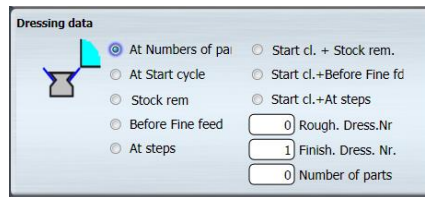
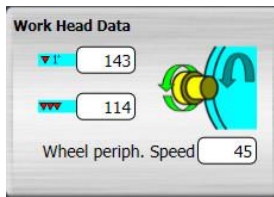

- **WHEELS:** These are already in memory.

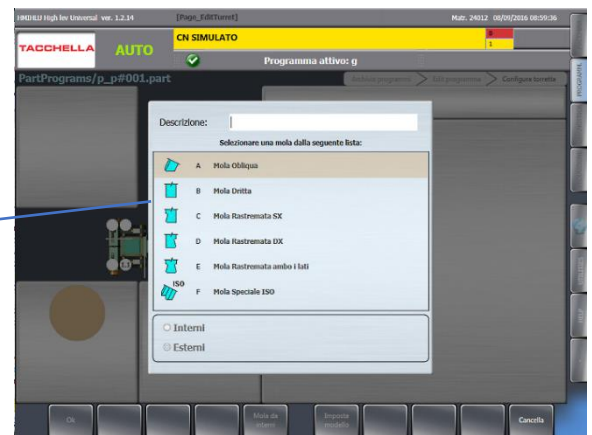
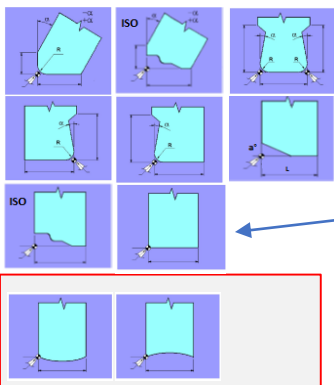

- **Grinding Cycles:** complete and flexible

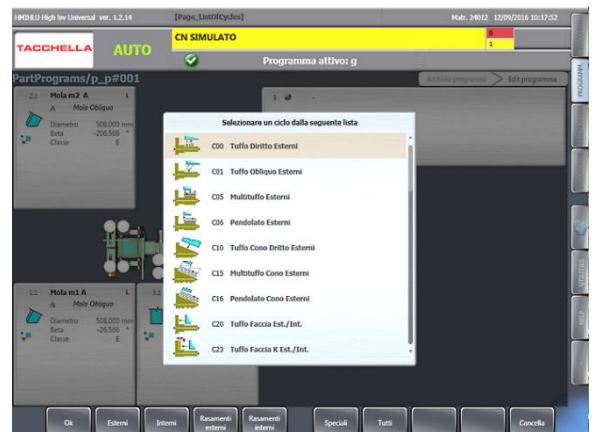
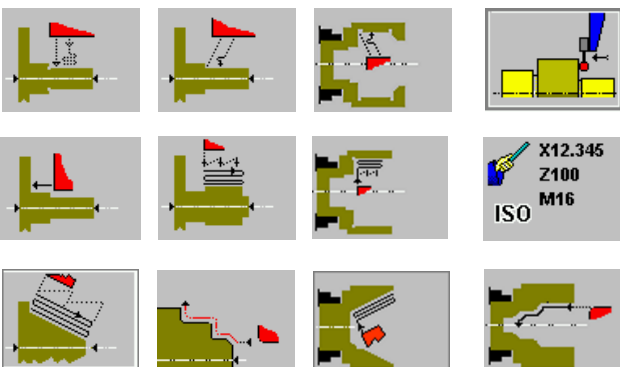

- INDUSTRY 4.0 offers machines with functionality that can connect with factory computers / server
- This includes :
 - Ethernet card or others protocols (TCP/IP standard)
 - Teleservice
 - Second diagnostic level CNC (functions and alarms in plain text)
 - Auto-set work data on machine CNC
 - Air-Gap Eliminator device
 - anti-crash Air-Gap
 - Safety Integrated Systems
 - Wheel wear compensation
- Possibility of:
 - Machine status control
 - Remote diagnosis and intervention
 - Continuous interaction with the machine

• Remote Control

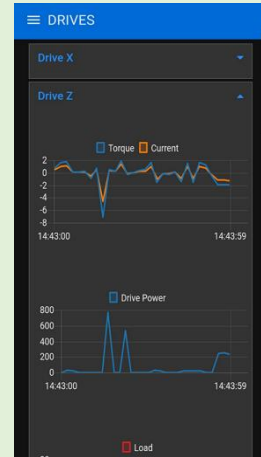

Note: See detailed description on the proposal



- Access / loading of Machine SW Backup data and / or any "Feed" of the SW Knowledge of the CNC configuration without a visit on site of our technicians
- Quick identification of the machine downtime with the possibility of immediate resolution via Tele-assistance or the possible sending of the specialized technician for the problem encountered
- Ethernet card for connection with remote PC -(optional TOP Stand-Alone software)

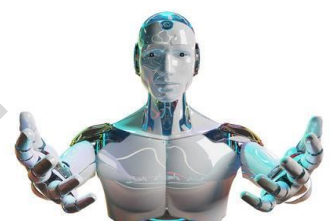
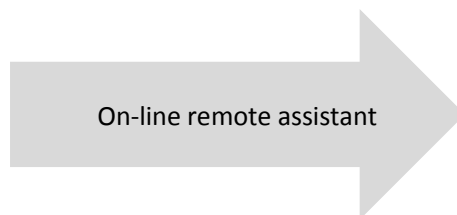

Series	2000	3000
Nominal Capacities		
Length between centers [mm]	2200	3000
Max. grindable length with left wheel at 0°[mm]	2000	3000
Max. grindable length with right wheel at 30°[mm]	1700	3000
Center Height [mm]	330 (525)*	
Max. grindable diameter [mm]	500 (1040)*	
Max. weight between centers [kg]	1000 - 1500 -2500	
Total installed power (approx.) Excluding accessories [kW]	60 --100	
Machine weight excluding accessories [kg]	20000	28000
WheelHead		
Max. external wheel diameter x thickness x ID [mm]	610x120x203 / (760 x 150 x 304,8)	
Wheel Spindle Power [kW]	22 (30)*	
Peripheral speed [m/sec]	50 (63)*	
Internal grinding	See accessories	
WheelHead swivelling system	B Axis	«turret» shaped
Max. work travel based on configuration (see tab.1 pag. 3)		
Axis Resolution [mm]	0,0001	
Transverse axis "X"		
Max. travel [mm]	470 (650)*	
Max. speed[m/min]	10	
Motor torque [Nm]	27	
Axis Resolution [mm]	0,0001	
Longitudinal axis "Z"		
Max. travel [mm]	2300	3280 (3550)*
Max. speed[m/min]	12	
Motor torque [Nm]	50	
Axis Resolution [mm]	0,0001	
WorkHead		
Attachment Taper Ext. / Int.	ASA 6 /{(11)* / Morse 5/(6)*	
Speed range [rpm]	10 ÷ 200	
Spindle torque [Nm]	50 ÷ 470 / (870)*	
Tailstock		
Attachment internal Taper	Morse 6	
Quill diameter [mm]	140	
Max. Quill stroke [mm]	120	
Workpiece cylindricity correction [mm]	± 2,5	
Note:		
*	Subject to technical verification of machine equipment	
**	Limitations can arise depending on the overall dimensions	
	Dimensions, weights and features may vary depending on the accessories chosen.	
Straightness	≤ 0,0035 /1550 mm	
Rated Voltage Three-phase current	400V ±10 % - 50Hz	

The final configuration of the machine may be adapted or modified basing on the latest project developments.



Ex : MH2000

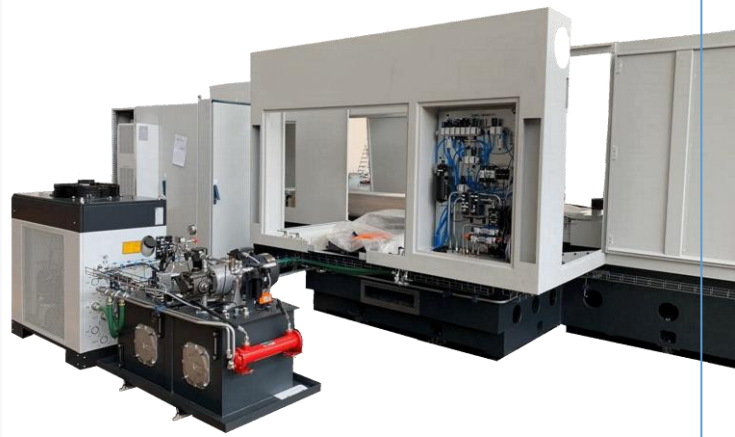

MH machines are designed for easy access from all sides for maintenance operation

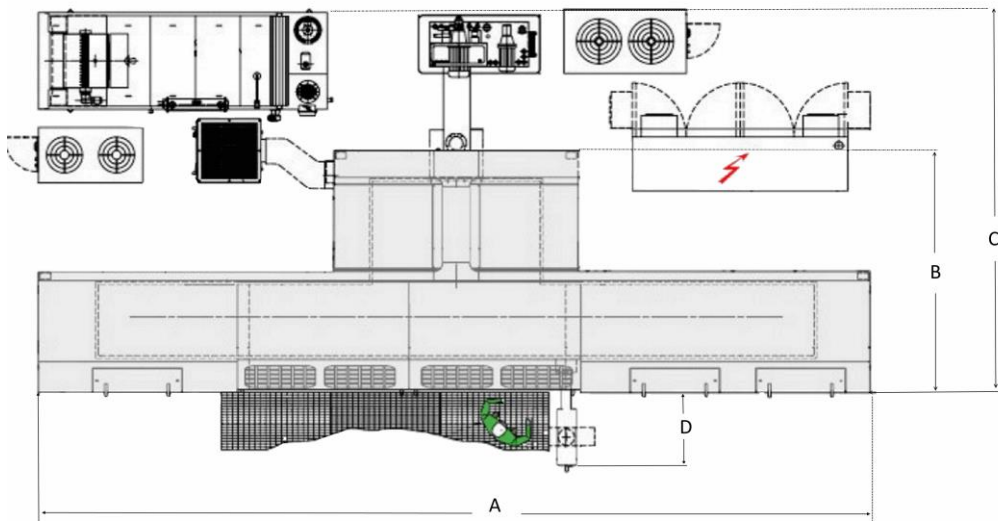
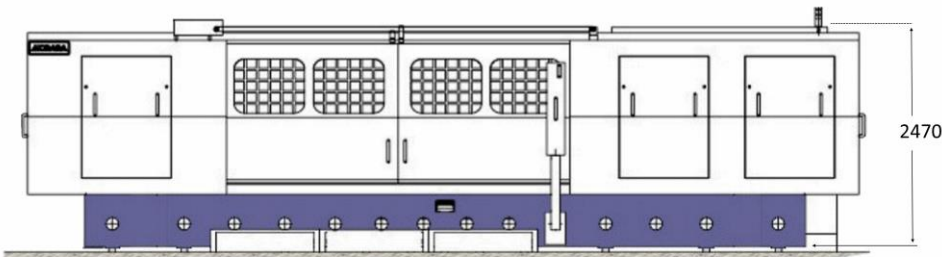
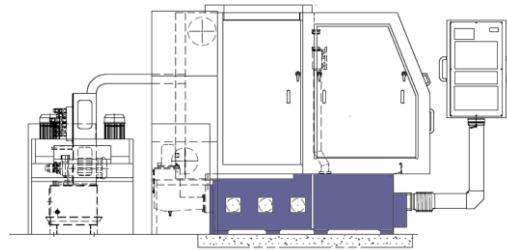

series	2000	3000
A	7700	9260
B	2700	2700 (2950)
C	4700	4700 (4950)
D	800	800

Note: The pictures shown are simply informative.
The final configuration of the machine may be adapted or modified basing on the latest project developments.



VDF BOEHRINGER

HESSAPP



meccanodora



MORARA

Pfiffner



TACHELLA

WITZIG & FRANK

About FFG Europe & Americas

The FFG entities in Europe and the Americas unite major players from the German, Italian, Swiss and American machine tool industry with a broad range of milling, turning, grinding, and gear manufacturing technology, and the knowhow of the renowned machine tool brands VDF Boehringer, Hessapp, IMAS, Jobs, MAG, Meccanodora, Modul, Morara, Pfiffner, Rambaudi, Sachman, Sigma, SMS, Tacchella and Witzig & Frank. Since 1798, these brands have substantially contributed to the progress in industrial manufacturing and are well known as reliable and innovative equipment and systems solutions suppliers for the automotive and truck, aerospace, machine building, general machining, railway industry, energy and heavy engineering industries. While being an independent group, these entities benefit from the strengths and opportunities of the global Fair Friend Group. They stand for premium technology within FFG.



FFG Europe & Americas
Grinding Technology Srl
OPERATIONAL HEADQUARTERS:
S.S. Valle Bormida Nord 4 –Cassino (AL)
Tel. 0144 71121

Grinding Technology – FFG Europe & Americas